

CVC1600 Automatic Cartoner

- Lower Operating Costs

- Increase Operating Flexibility

- Unparalleled Service

- Quality that your Customers Demand



The CVC1600 Automatic Cartoner is a compact, intermittent motion machine designed to form, load, and close various types of cartons. The 1600 is adaptable with standard assemblies for running bottles, tubes, or blister cards. Available options include Leaflet insertion and lot/date code embossing on the carton flap. The base machine is designed to run tuck closures but glue closure options are available. The 1600 can be run stand alone or integrated as part of an automated packaging line.

Cartoners

- Compact Design • Stainless Steel Construction • Economical Value • Quick & Easy Change Over

Solid Dose Bottling Lines
Blister Packaging
Labelers

"Leading Global Equipment Supplier"

www.cvcusa.com



CVC Technologies, Inc.

CVC1600 Technical Specifications

Standard Features:

- Stainless Steel Construction
- Flexible Changeover
- Adjustable Bucket Style Conveyor
- Manual or Auto Loading
- Tuck Closures
- Rate: 20-60 Cartons per minute

Options:

- Glue Closure (Nordson)
- Leaflet Insertion
- Lot/Date Code embossing on Carton Flap
- In-feed/Out-feed Conveyor

Carton Specifications:

- Width: 3/4" to 4" (19mm to 101mm)
- Length: 2" to 8-1/2" (50mm to 216mm)
- Height: 3/4" to 2-3/4" (19mm to 70mm)

Leaflet Specifications:

- Width: 3/4" to 1-1/2" (19mm to 38mm)
- Length: 2-3/4" to 8-1/4" (70mm to 209mm)

Machine Specifications:

- Weight: 1,587lbs (720kgs)
- Dimensions (in): (W)38 x (L)101 x (H)57
- Dimensions (mm): (W)960 x (L)2575 x (H)1440

Power and Air Requirements:

- Power Source: 220V, 50/60Hz, Single Phase
- Power Consumption: 7AMP
- Air Pressure: Minimum 87psi
- Air Volume: 1 cfm (*Plant air must be dry and clean)

Machine Layouts:

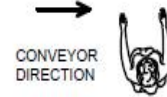
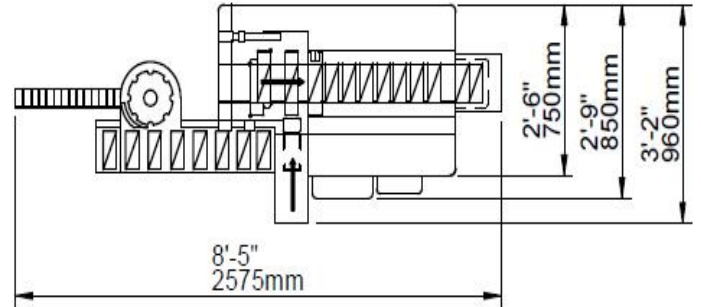

Top View

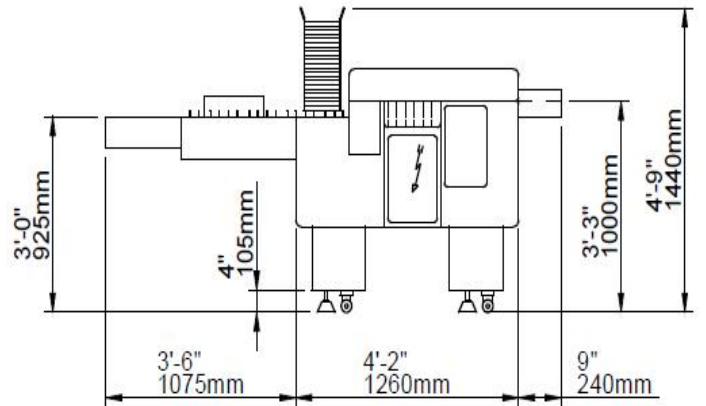

Front View



Quality • Value • Service

Authorized CVC Dealer

Certified Machinery Inc.
3175 Princeton Pike
Lawrenceville, NJ 08648
609-912-0300

www.certifiedmachinery.com

Copyright © CVC Technologies, Inc. • Jan. 2012 Edition

Dimensions shown are for a standard machine. This machine can run independently or can be integrated into an automated packaging line. All CVC equipment is covered by a one year parts warranty. Full Warranty details are included in our equipment proposals or can be found on our website.